

MD Bassoon Reed Tip Profiler

Instruction and User Manual

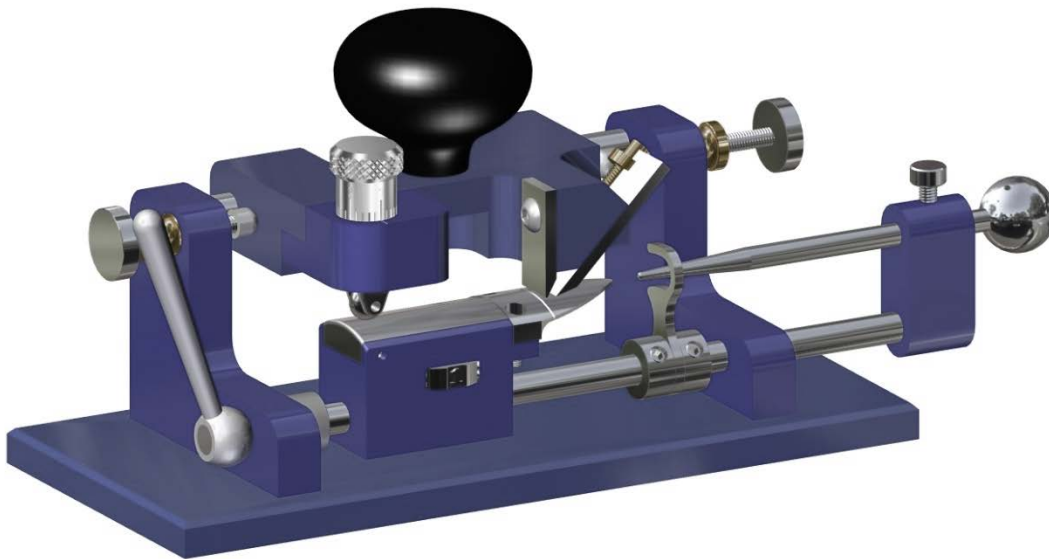

**By
MD Reed Products**

Table of Contents

Limited Warranty 2
Product Description 3
Preparing the tip profiler for use 6
Using the tip profiler 7
Adjusting the Angle of the Template 8
Adjusting the Carriage Bearing 8
Removing, Installing, and Adjusting the blade 10
Thickness Adjustment 11

Limited Warranty

The MD Bassoon Reed Tip Profiler is covered by a limited 1 year warranty from the date of delivery. Every effort is made to produce a machine of the highest quality. If you find defects in the materials or workmanship of any part of the machine that affect the proper function of the machine, MD Reed Products will either repair or replace all necessary parts at no charge.

What is not covered?

Any defect or problem that is caused by abuse, misuse, or an act of nature (such as a flood) is not covered. This also includes defects caused by the failure to follow the instructions provided in this manual. Consequential and incidental damages are not recoverable under this warranty. Cosmetic defects are also not covered. MD Reed Products does not provide refunds.

How to get service:

Contact MD Reed Products by email at paul@mdreedproducts.com, by phone at 888-540-5530, or by mail at:

MD Reed Products
129 W. Minneapolis Ave.
Salina, KS 67401

Some issues will allow for the defective part to be returned to MD Reed Products and some will require that the entire machine be returned. MD Reed Products reserves the right to make this determination.

Product Description

The MD Bassoon Reed Tip Profiler from MD Reed Products gives the user the ability to quickly and easily adjust the thickness of the reed as well as the angle of the profile. The MD Tip Profiler not only provides maximum adjustability, it also allows the user to return to previous settings or select new settings without tools and without disassembling any components.

In addition to the features found on most tip profilers, the MD Tip Profiler is equipped with an adjustment knob that allows for the angle of the template to be adjusted from zero to 3 degrees. The knob is numbered 1 to 8, with each number representing an angle of $\frac{3}{8}$ of a degree. The knob will also stop between numbers, giving the user an angle adjustment of $\frac{3}{16}$ of a degree for each click. The carriage bearing subassembly is also adjustable relative to the carriage, allowing for different portions of the template to be used.

Part Terms:

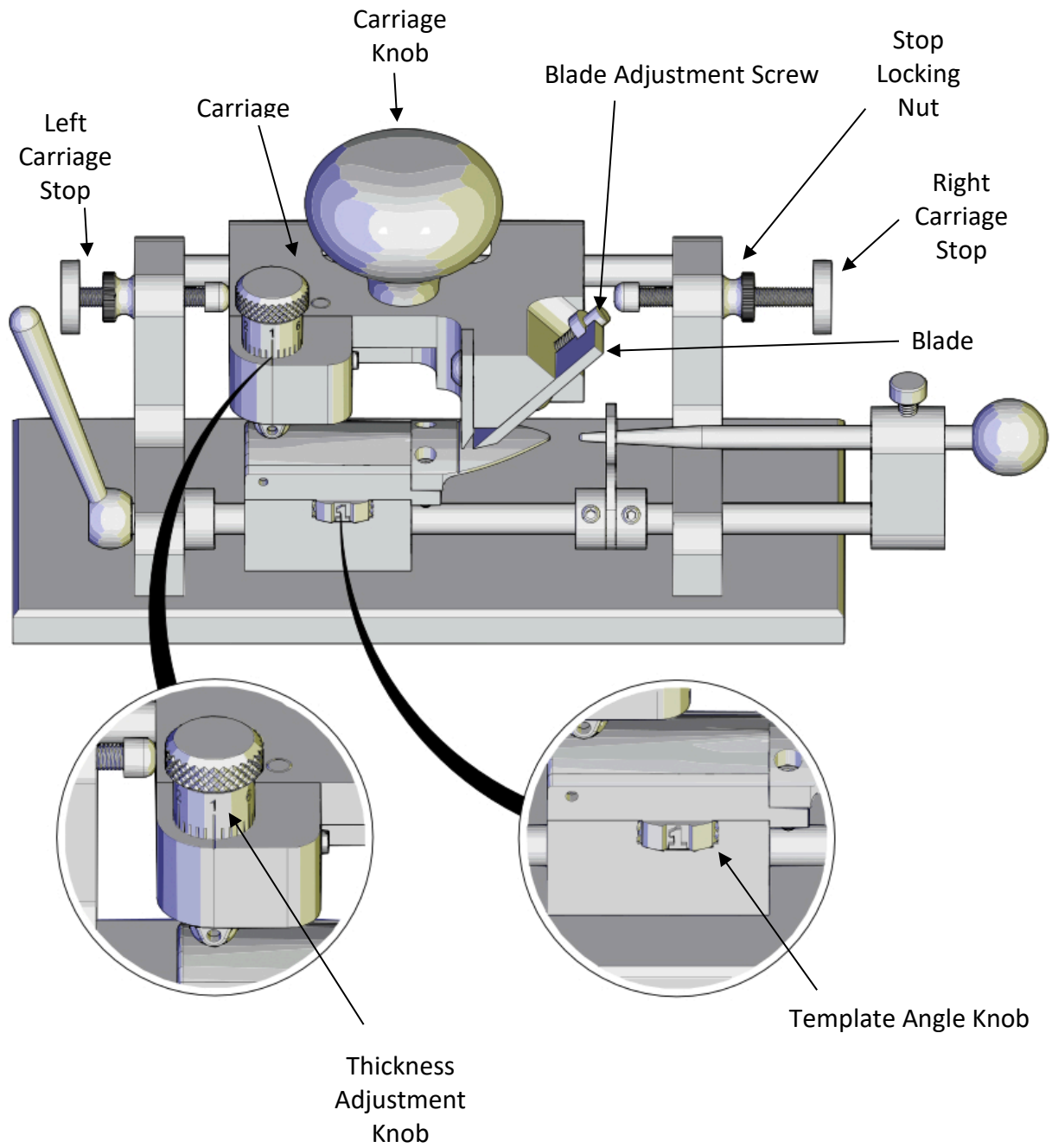

Part Terms (cont.):

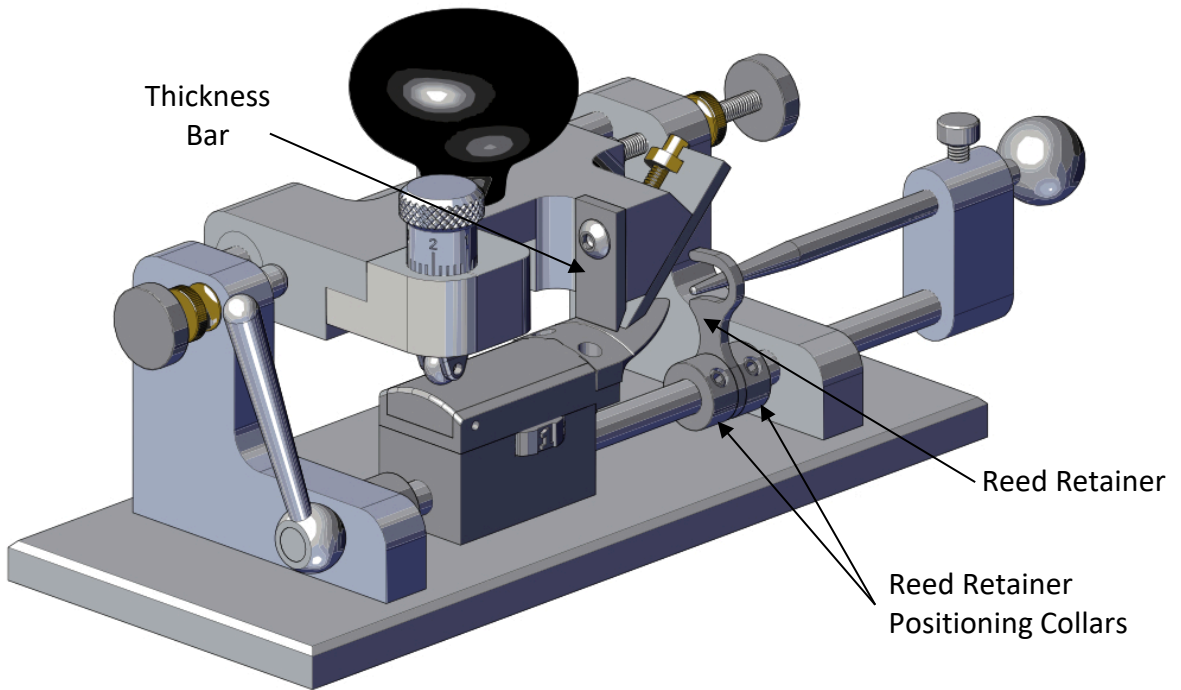
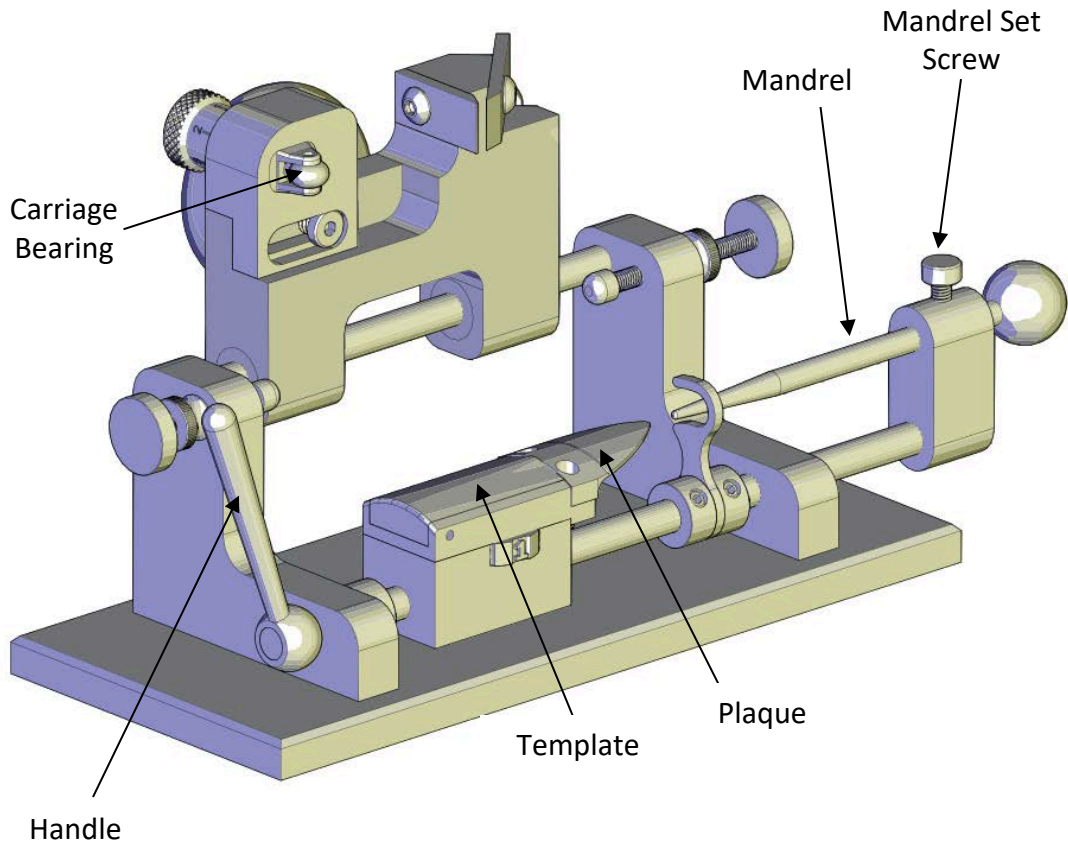

Preparing the tip profiler for use

Adjusting the left carriage stop:

Your MD Tip Profiler is adjusted prior to shipment so that the carriage stops when the blade cuts to the tip of the reed. However, should the stop need adjustment, follow these steps:

1. Loosen the stop locking nut and turn it 3-4 turns in the counterclockwise direction. If you find that it is difficult to turn the stop locking nut, turn the carriage stop knob to counterclockwise until it becomes loose.

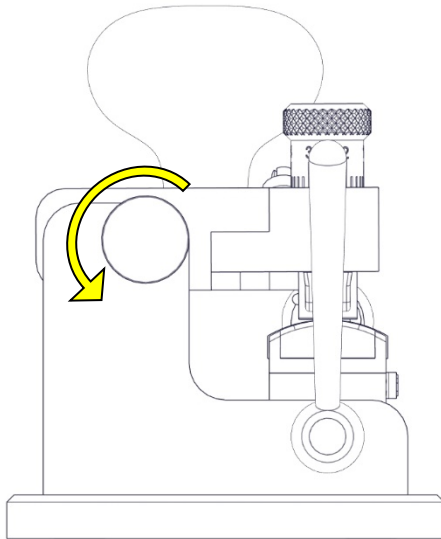

2. Slide the blade carrier forward until it contacts the center stop and look down onto the plaque and from the top of the profiler. Turn the carriage stop knob clockwise until the leading edge of the blade aligns with the etch mark on the plaque. Tighten the stop locking nut to prevent the carriage stop knob from moving during use.

Adjusting the right carriage stop:

1. The machine is adjusted prior to shipment to profile a distance of approximately 3/8 inch (10mm). If you desire a different profile (scrape) length, begin by loosening the stop locking knob on the right carriage stop, as described above.
2. Push the carriage to the right until it is contact with the carriage stop. Turn the carriage stop knob either clockwise or counter-clockwise until the leading edge of the blade is in the position in which you wish to start profiling. Tighten the stop locking nut to prevent the carriage stop knob from moving during use.

Further machine adjustments are best made after a few reeds are profiled so that you have a good starting point.

Using the tip profiler

1. The tip profiler works best with soaked reeds because it allows the reed to conform to the plaque better than a dry reed. Loosen the mandrel set screw and slide the mandrel to the right (away from the machine). Start the reed onto the plaque and, while holding the reed, push the mandrel into the reed as far as it will go:

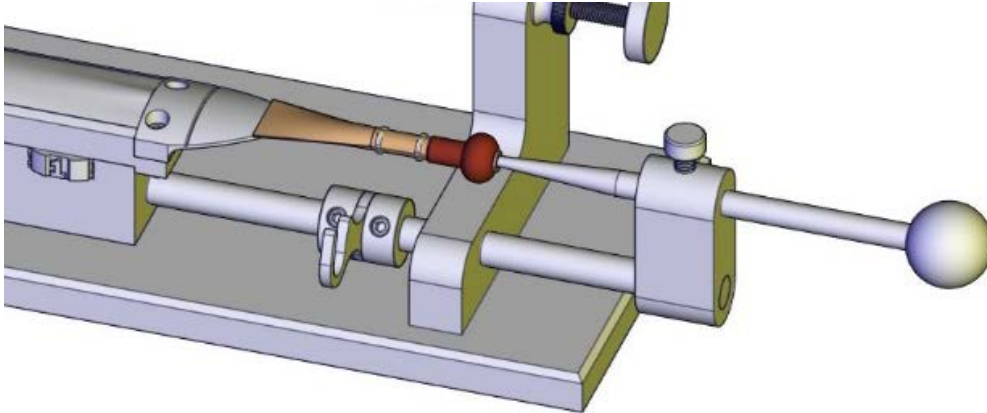

Then push the mandrel to the left, moving the reed on the plaque until it reaches the etch mark on the plaque:

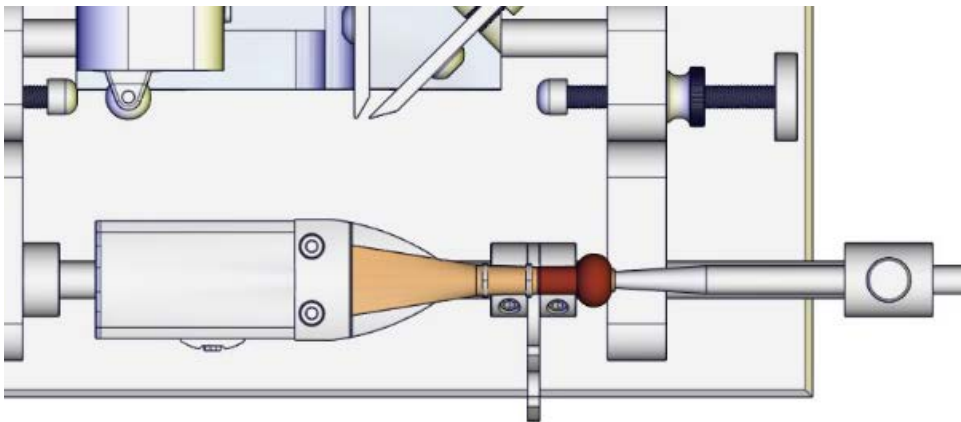

Rotate the reed retainer until it fits snugly around the reed.

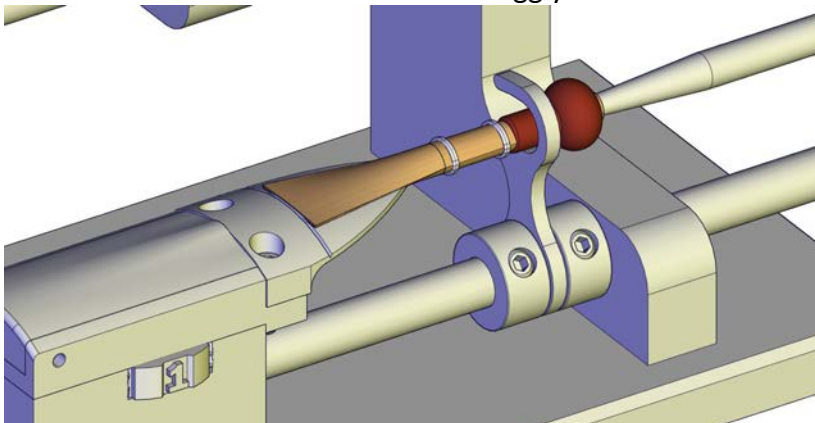

If the retainer location needs adjustment, loosen the set screws in the positioning collars and move the collars and retainer to the desired position and tighten the set screws. The location of the retainer doesn't matter as long as it prevents the reed from sliding to the left during profiling (i.e. before the first wire, second wire, or the wrap the covers the third wire).

To begin the profiling process, grasp the carriage knob and slide the carriage to the right until it contacts the right carriage stop. Rotate the handle until one edge of the reed is underneath the blade and then rotate the carriage down until the blade is in contact with the reed. Begin profiling by sliding the carriage forward. Only slight downward pressure is needed (little more than the weight of the carriage) while making a cut. After a cut is made, lift the carriage slightly and slide it back to the right until it once again makes contact with the right carriage stop. Rotate the handle slightly so that the next profiling stroke is cutting with an overlap of approximately 50% over the previous cut. Continue in this manner until the all of the reed blade is profiled. Repeat this process for the other reed blade. The carriage bearing may or may not contact the template until profiling is complete. The thickness bar prevents this, allowing only .003 to .004 inches (.08mm to .10mm) of cane to be removed during one pass.

Adjusting the Angle of the Template

The MD Bassoon Reed Tip Profiler allows you to adjust the angle of the template, the purpose of which is to provide a seamless transition from the original scrape of the reed to the new scrape created by the tip profiler. If you use the tip profiler and notice that it created an undesirable line where the profiling started, adjusting the angle of the template will solve this problem. The number "1" setting represents a zero degree angle, while the number "8" setting is angle of three degrees. Each number is 3/8 of a degree (i.e. number 2 is an angle of 3/8, number 3 is an angle of 3/4, number 4 is 1-1/8, etc.). The knob has indentations between each number as well, for finer adjustment. To adjust the angle, simply turn the knob. While the knob is capable of turning more than 360 degrees, it does not continue to increase the angle. In other words, turning the knob from 8 to 1 resets the angle from three degrees to zero degrees.

Adjusting the Carriage Bearing

The subassembly that contains the carriage bearing (highlighted in yellow in the image below) is independently adjustable relative to the carriage, which allows for different portions of the template to be used during profiling. The range of adjustment is 5/8" (16mm).

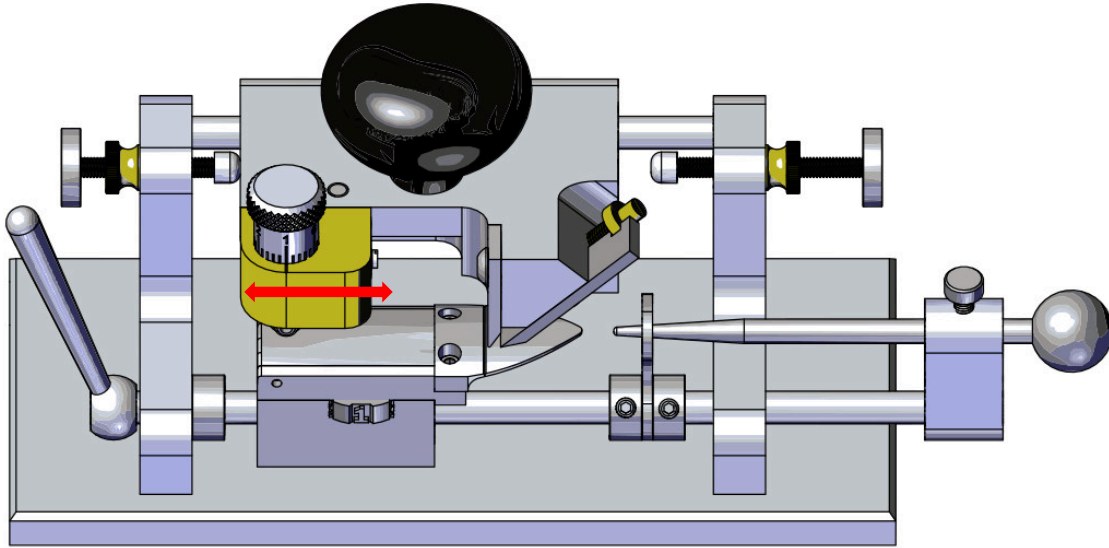

Making an adjustment is easily done by rotating the carriage up to expose the underside of the carriage and loosening the screw with a 1/8" allen key.

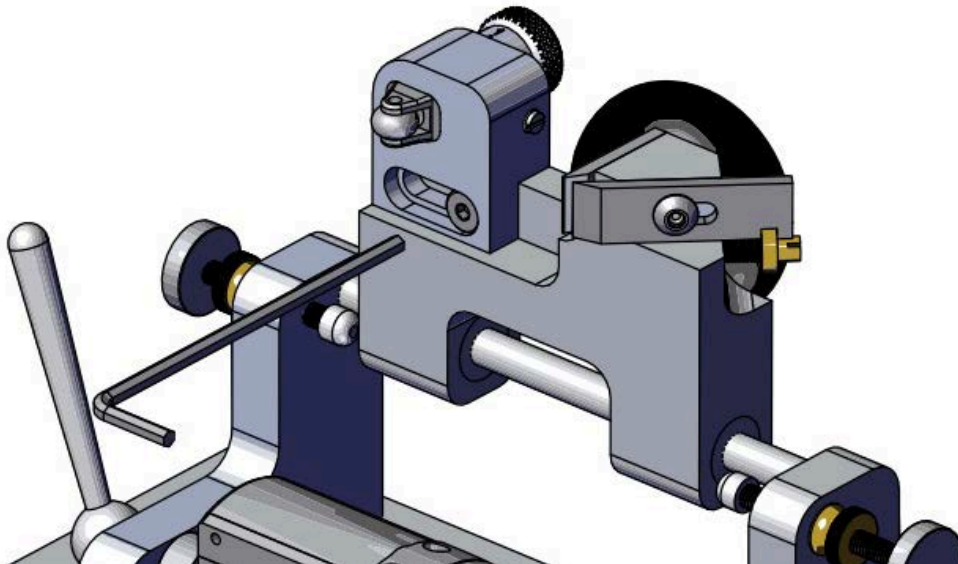

Next, slide the carriage bearing subassembly to the desired position and tighten the screw.

Removing, Installing, and Adjusting the blade



WARNING! The tip profiler blade is very sharp and must be handled with care to avoid injury.

1. The blade in the MD Tip Profiler is made from tool steel. During normal use, it will hold a sharp edge for a very long time. When it does need to be sharpened, MD Reed Products offers free sharpening. To remove the blade, loosen and remove the screw holding the blade using a 1/8" allen key.

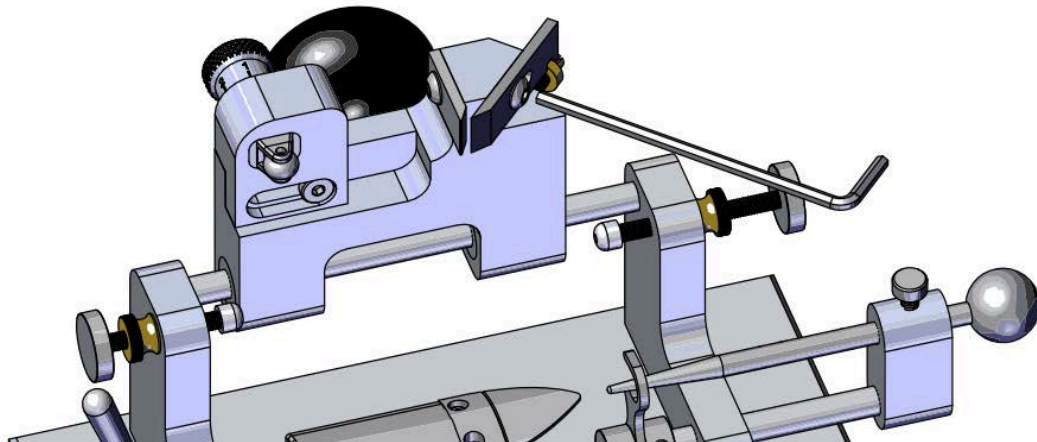

2. When installing a blade, position the blade so that the notch in the blade engages with the blade adjustment screw. Apply pressure to the side of the blade, forcing it against the inside edge of the carriage. Install the screw until you feel resistance and stop. It should be tight enough that the blade stays in position, but no more.

3. Turn the blade adjustment screw until the blade is just slightly below the thickness bar. Turning the screw clockwise lowers the blade relative to the thickness bar and counterclockwise raises it.

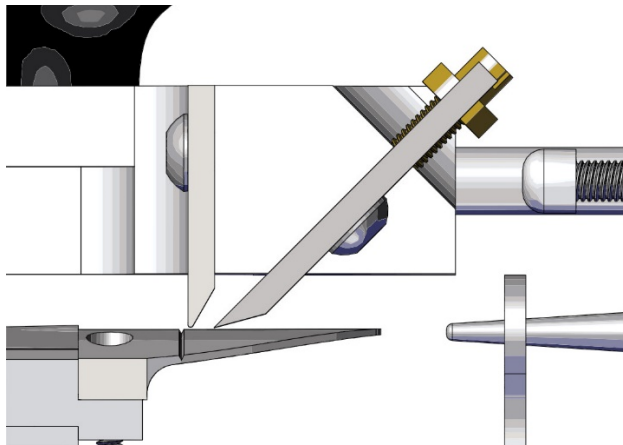

4. Make a test cut with a reed. Make any adjustments needed and fully tighten the blade screw.

Thickness Adjustment

The profiled thickness is adjustable by turning the thickness adjustment knob. Turning the knob clockwise results in a thinner profile while turning it counterclockwise results in a thicker profile. Each click of the knob equals .0012" (0.03mm) of thickness change.

